

LM723JAN

Voltage Regulator

General Description

The LM723 is a voltage regulator designed primarily for series regulator applications. By itself, it will supply output currents up to 150 mA; but external transistors can be added to provide any desired load current. The circuit features extremely low standby current drain, and provision is made for either linear or foldback current limiting.

The LM723 is also useful in a wide range of other applications such as a shunt regulator, a current regulator or a temperature controller.

Features

- 150 mA output current without external pass transistor
- Output currents in excess of 10A possible by adding external transistors
- Input voltage 40V max
- Output voltage adjustable from 2V to 37V
- Can be used as either a linear or a switching regulator

Ordering Information

NS PART NUMBER	SMD PART NUMBER	NS PACKAGE NUMBER	PACKAGE DISCRIPTION
JL723BIA	JM38510/10201BIA	H10C	10LD Metal Can
JL723SCA	JM38510/10201SCA	J14A	14LD CERDIP
JL723SIA	JM38510/10201SIA	H10C	10LD Metal Can

Connection Diagrams

Dual-In-Line Package

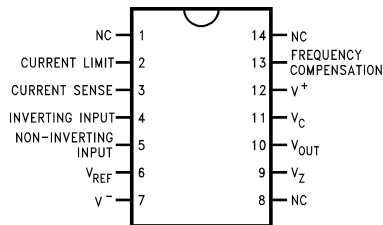

Top View
See NS Package J14A

20125802

Metal Can Package

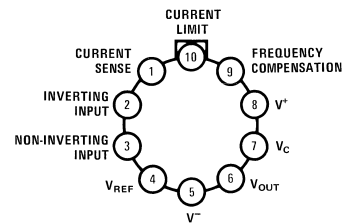

Note: Pin 5 connected to case.
Top View
See NS Package H10C

20125803

Equivalent Circuit*

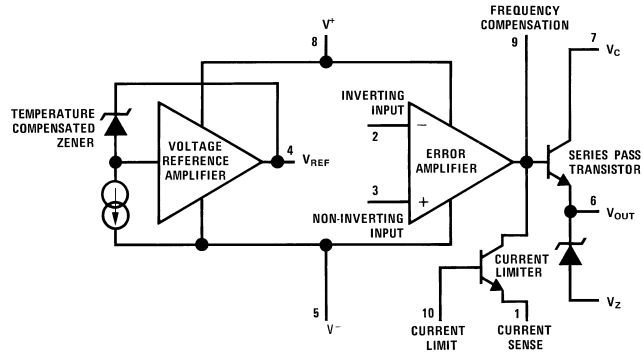

20125804

*Pin numbers refer to metal can package.

Schematic Diagram

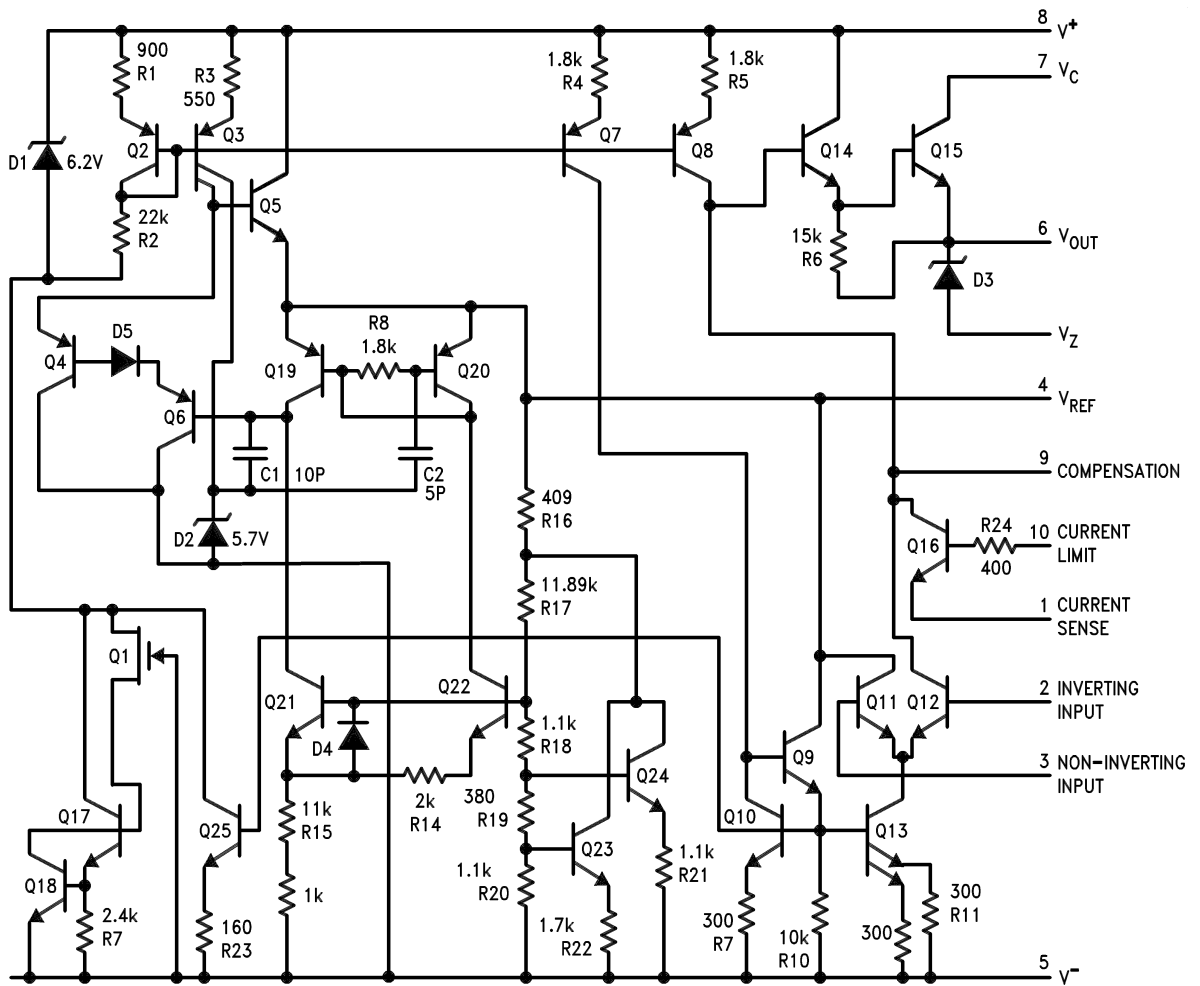

20125801

Absolute Maximum Ratings (Note 1)

Pulse Voltage from V^+ to V^- (50 ms)	50V
Continuous Voltage from V^+ to V^-	40V
Input-Output Voltage Differential	40V
Differential Input Voltage	$\pm 5V$
Voltage between non-inverting input and V^-	+8V
Current from V_Z	25 mA
Current from V_{REF}	15 mA
Internal Power Dissipation ($T_A = 125^\circ C$)	
Metal Can (Note 2)	300 mW
Cavity DIP (Note 2)	400 mW
Maximum T_J	+175°C
Storage Temperature Range	$-65^\circ C \leq T_A \leq +150^\circ C$
Lead Temperature (Soldering, 4 sec. max.)	300°C
Thermal Resistance	
θ_{JA}	
Cerdip (Still Air)	100°C/W
Cerdip (500LF/ Min Air flow)	61°C/W
Metal Can (Still Air)	156°C/W
Metal Can (500LF/ Min Air flow)	89°C/W
θ_{JC}	
CERDIP	22°C/W
Metal Can	37°C/W
ESD Tolerance (Note 3)	1200V

Recommended Operating Conditions

Input Voltage Range	9.5V to 40V _{DC}
Output Voltage Range	2V to 37V _{DC}
Input-Output Voltage Differential	2.5 V to 38V _{DC}
Ambient Operating Temperature Range	$-55^\circ C \leq T_A \leq +125^\circ C$

Quality Conformance Inspection

MIL-STD-883, Method 5004 and Method 5005

Subgroup	Description	Temp (°C)
1	Static tests at	+25
2	Static tests at	+125
3	Static tests at	-55
4	Dynamic tests at	+25
5	Dynamic tests at	+125
6	Dynamic tests at	-55
7	Functional tests at	+25
8A	Functional tests at	+125
8B	Functional tests at	-55
9	Switching tests at	+25
10	Switching tests at	+125
11	Switching tests at	-55

Electrical Characteristics

DC Parameters (Note 9)

Symbol	Parameter	Conditions	Notes	Min	Max	Units	Sub-groups	
V_{Rline}	Line Regulation	$12V \leq V_{IN} \leq 15V, V_{OUT} = 5V,$ $I_L = 1mA$		-0.1	0.1	% V_{OUT}	1	
				-0.2	0.2	% V_{OUT}	2	
				-0.3	0.3	% V_{OUT}	3	
			$12V \leq V_{IN} \leq 40V, V_{OUT} = 2V,$ $I_L = 1mA$		-0.2	0.2	% V_{OUT}	1
			$9.5V \leq V_{IN} \leq 40V, V_{OUT} = 5V,$ $I_L = 1mA$		-0.3	0.3	% V_{OUT}	1
			$12V \leq V_{IN} \leq 15V, V_{OUT} = 5V,$ $I_L = 1mA$		-10.0	+10.0	mV	1
				-20.0	+20.0	mV	2	
				-30.0	+30.0	mV	3	
V_{Rload}	Load Regulation	$1mA \leq I_L \leq 50mA, V_{IN} = 12V,$ $V_{OUT} = 5V$		-0.15	0.15	% V_{OUT}	1	
				-0.4	0.4	% V_{OUT}	2	
				-0.6	0.6	% V_{OUT}	3	
			$1mA \leq I_L \leq 10mA, V_{IN} = 40V,$ $V_{OUT} = 37V$		-0.5	0.5	% V_{OUT}	1
			$6mA \leq I_L \leq 12mA, V_{IN} = 10V,$ $V_{OUT} = 7.5V$		-0.2	0.2	% V_{OUT}	1
			$1mA \leq I_L \leq 50mA, V_{IN} = 12V,$ $V_{OUT} = 5V$		-15.0	+15.0	mV	1
				-40.0	+40.0	mV	2	
				-60.0	+60.0	mV	3	
V_{REF}	Voltage Reference	$I_{REF} = 1mA, V_{IN} = 12V$		6.95	7.35	V	1	
				6.9	7.4	V	2, 3	
I_{SCD}	Standby Current	$V_{IN} = 30V, I_L = I_{REF} = 0,$ $V_{OUT} = V_{REF}$		0.5	3	mA	1	
				0.5	2.4	mA	2	
				0.5	3.5	mA	3	
I_{OS}	Short Circuit Current	$V_{OUT} = 5V, V_{IN} = 12V,$ $R_{SC} = 10\Omega, R_L = 0$		45	85	mA	1	
V_Z	Zener Voltage	$I_Z = 1mA$	(Notes 8, 10)	5.58	6.82	V	1	
V_{OUT}	Output Voltage	$V_{IN} = 12V, V_{OUT} = 5V, I_L = 1mA$	(Note 11)	4.5	5.5	V	1, 2, 3	
Delta V_{OUT} / Delta T	Average Temperature Coefficient of Output Voltage	$25^\circ C \leq T_A \leq +125^\circ C, V_{IN} = 12V,$ $V_{OUT} = 5V, I_L = 1mA$	(Note 12)	-0.01	0.01	%/ $^\circ C$	8A	
		$-55^\circ C \leq T_A \leq +25^\circ C, V_{IN} = 12V,$ $V_{OUT} = 5V, I_L = 1mA$	(Note 12)	-0.015	0.015	%/ $^\circ C$	8B	
Delta V_{OUT} / Delta V_{IN}	Ripple Rejection	$f = 10KHz, C_{REF} = 0F,$ $V_{INS} = 2V_{RMS}$		64		dB	4	
		$f = 10KHz, C_{REF} = 5\mu F,$ $V_{INS} = 2V_{RMS}$		76		dB	4	
N_O	Output Noise Voltage	$100Hz \leq f \leq 10KHz,$ $V_{INS} = 0V_{RMS}, C_{REF} = 0\mu F$			120	μV_{RMS}	4	
		$100Hz \leq f \leq 10KHz,$ $V_{INS} = 0V_{RMS}, C_{REF} = 5\mu F$			7	μV_{RMS}	4	
Delta V_{OUT} / Delta V_{IN}	Line Transient Response	$V_{IN} = 12V, V_{OUT} = 5V,$ $I_L = 1mA, C_{REF} = 5\mu F,$ $R_{SC} = 0\Omega,$ Delta $V_{IN} = 3V$ for 25 μ sec		0	10	mV/V	4	

Electrical Characteristics (Continued)

DC Parameters (Note 9)

Symbol	Parameter	Conditions	Notes	Min	Max	Units	Sub-groups
Delta V_{OUT} / Delta I_L	Load Transient Response	$V_{IN} = 12V$, $V_{OUT} = 5V$, $I_L = 40mA$, $C_{REF} = 5\mu F$, $R_{SC} = 0\Omega$, Delta $I_L = 10mA$ for 25 μ sec		-1.5	0	mV/mA	4

DC Parameters: Drift Values

Delta calculations performed on JAN S and QMLV devices at Group B, Subgroup 5, only.

Symbol	Parameters	Conditions	Notes	Min	Max	Unit	Sub-groups
V_{Rline}	Line Regulation	$12V \leq V_{IN} \leq 15V$, $V_{OUT} = 5V$, $I_L = 1mA$, $\pm 1mV$, or $\pm 15\%$ (whichever is greater)		-1.0	1.0	mV	1
V_{Rload}	Load Regulation	$1mA \leq I_L \leq 50mA$, $V_{IN} = 12V$, $V_{OUT} = 5V$, $\pm 1mV$, or $\pm 20\%$ (whichever is greater)		-1.0	1.0	mV	1
V_{REF}	Reference Voltage	$I_{REF} = 1mA$, $V_{IN} = 12V$		-15	15	mV	1
I_{SCD}	Standby Current Drain	$V_{IN} = 30V$, $I_L = I_{REF} = 0$, $V_{OUT} = V_{REF}$		-10	10	%	1

Note 1: "Absolute Maximum Ratings" indicate limits beyond which damage to the device may occur. Operating Ratings indicate conditions for which the device is functional, but do not guarantee specific performance limits. For guaranteed specifications and test conditions, see the Electrical Characteristics. The guaranteed specifications apply only for the test conditions listed. Some performance characteristics may degrade when the device is not operated under the listed test conditions.

Note 2: The maximum power dissipation for these devices must be derated at elevated temperatures and is dictated by T_{JMAX} , θ_{JA} , and the ambient temperature, T_A . The maximum available power dissipation at any temperature is $P_d = (T_{JMAX} - T_A)/\theta_{JA}$ or the number given in the Absolute Maximum Ratings, whichever is less. See derating curves for maximum power rating above 25°C.

Note 3: Human body model, 1.5 k Ω in series with 100 pF.

Note 4: L_1 is 40 turns of No. 20 enameled copper wire wound on Ferroxcube P36/22-3B7 pot core or equivalent with 0.009 in. air gap.

Note 5: Figures in parentheses may be used if R1/R2 divider is placed on opposite input of error amp.

Note 6: Replace R1/R2 in figures with divider shown in Figure 13.

Note 7: V^+ and V_{CC} must be connected to a +3V or greater supply.

Note 8: For metal can applications where V_Z is required, an external 6.2V zener diode should be connected in series with V_{OUT} .

Note 9: Unless otherwise specified, $T_A = 25^\circ C$, $V_{IN} = V^+ = V_C = 12V$, $V^- = 0$, $V_{OUT} = 5V$, $I_L = 1mA$, $R_{SC} = 0$, $C_1 = 100pF$, $C_{REF} = 0$ and divider impedance as seen by error amplifier $\leq 10k\Omega$ connected as shown in Figure 1. Line and load regulation specifications are given for the condition of constant chip temperature. Temperature drifts must be taken into account separately for high dissipation conditions.

Note 10: Tested for 14 – lead DIP only.

Note 11: Setup test for Temp. Coeff.

Note 12: Calculated parameter

Typical Performance Characteristics

Load Regulation Characteristics with Current Limiting

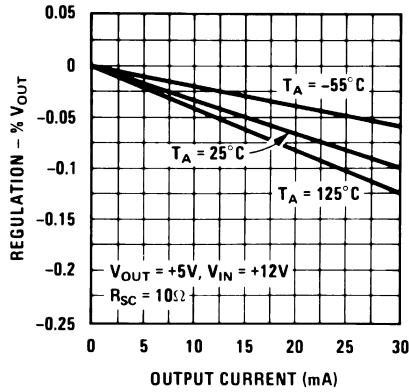

20125822

Load Regulation Characteristics with Current Limiting

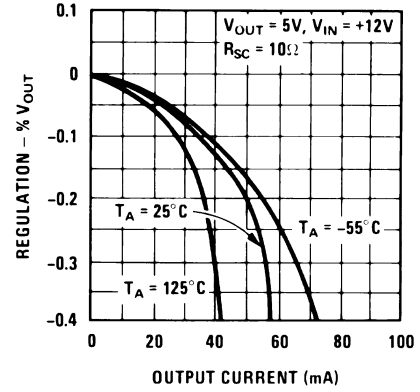

20125823

Load & Line Regulation vs Input-Output Voltage Differential

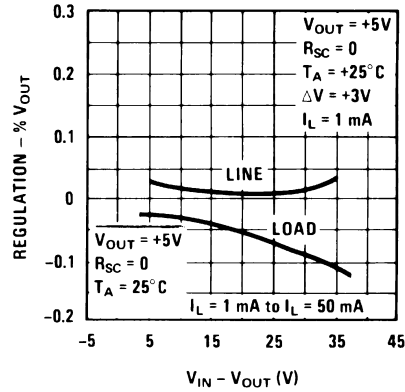

20125824

Current Limiting Characteristics

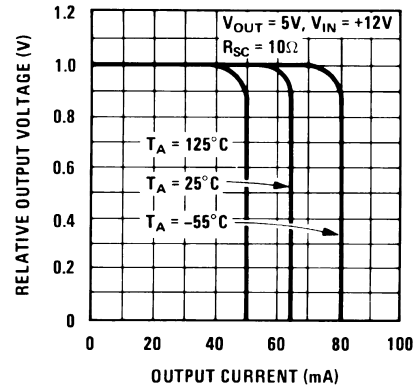

20125825

Current Limiting Characteristics vs Junction Temperature

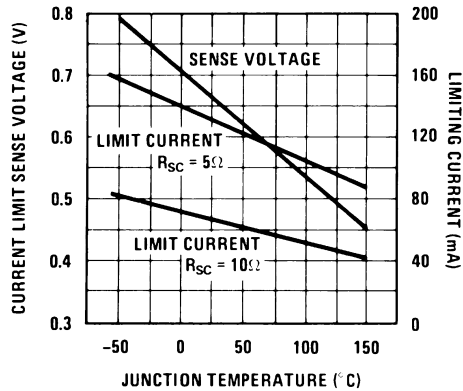

20125826

Standby Current Drain vs Input Voltage

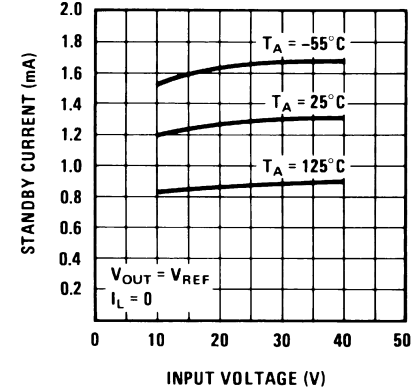

20125827

Typical Performance Characteristics (Continued)

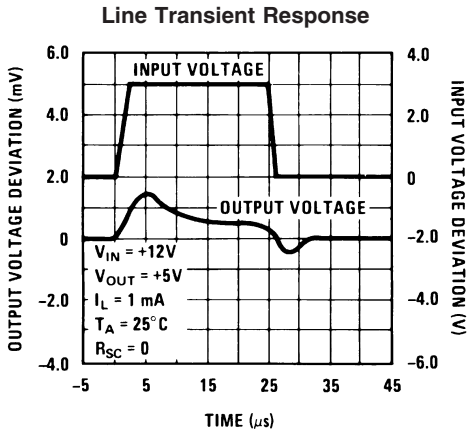

20125828

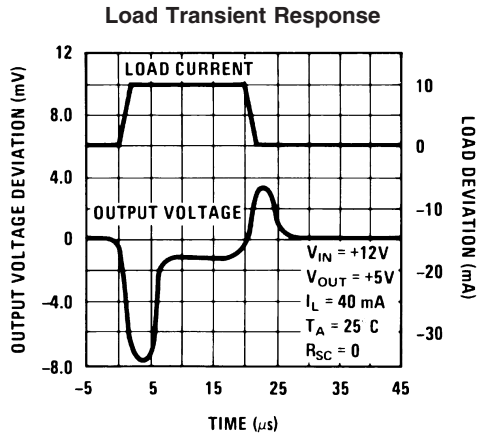

20125829

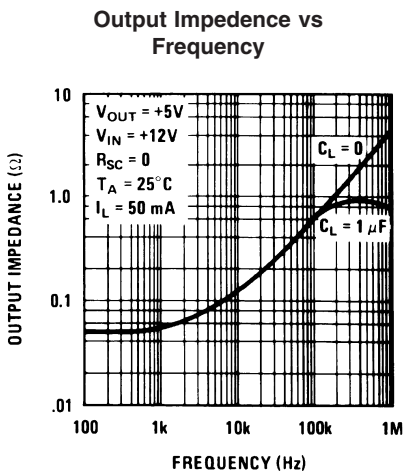

20125830

Maximum Power Ratings

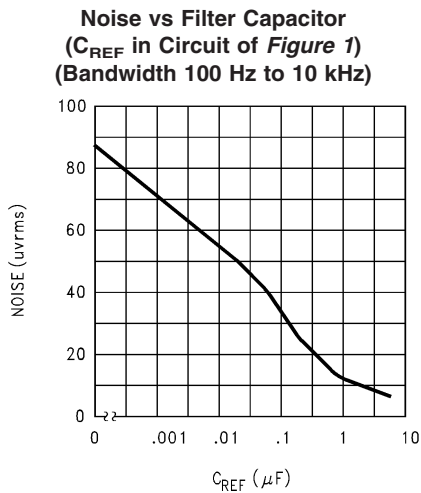

20125831

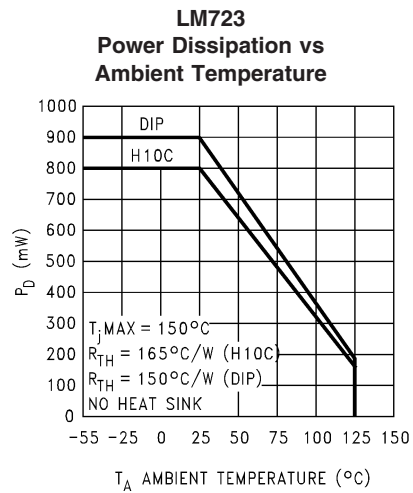

20125832

TABLE 1. Resistor Values (kΩ) for Standard Output Voltage

Positive Output Voltage	Applicable Figures (Note 5)	Fixed Output ±5%		Output Adjustable ±10% (Note 6)			Negative Output Voltage	Applicable Figures	Fixed Output ±5%		5% Output Adjustable ±10%		
		R1	R2	R1	P1	R2			R1	R2	R1	P1	R2
+3.0	1, 5, 6, 9, 12 (4)	4.12	3.01	1.8	0.5	1.2	+100	7	3.57	102	2.2	10	91
+3.6	1, 5, 6, 9, 12 (4)	3.57	3.65	1.5	0.5	1.5	+250	7	3.57	255	2.2	10	240
+5.0	1, 5, 6, 9, 12 (4)	2.15	4.99	0.75	0.5	2.2	-6 (Note 7)	3, (10)	3.57	2.43	1.2	0.5	0.75
+6.0	1, 5, 6, 9, 12 (4)	1.15	6.04	0.5	0.5	2.7	-9	3, 10	3.48	5.36	1.2	0.5	2.0
+9.0	2, 4, (5, 6, 9, 12)	1.87	7.15	0.75	1.0	2.7	-12	3, 10	3.57	8.45	1.2	0.5	3.3
+12	2, 4, (5, 6, 9, 12)	4.87	7.15	2.0	1.0	3.0	-15	3, 10	3.65	11.5	1.2	0.5	4.3
+15	2, 4, (5, 6, 9, 12)	7.87	7.15	3.3	1.0	3.0	-28	3, 10	3.57	24.3	1.2	0.5	10
+28	2, 4, (5, 6, 9, 12)	21.0	7.15	5.6	1.0	2.0	-45	8	3.57	41.2	2.2	10	33
+45	7	3.57	48.7	2.2	10	39	-100	8	3.57	97.6	2.2	10	91
+75	7	3.57	78.7	2.2	10	68	-250	8	3.57	249	2.2	10	240

TABLE 2. Formulae for Intermediate Output Voltages

Outputs from +2 to +7 volts <i>(Figures 1, 4, 5, 6, 9, 12)</i> $V_{OUT} = \left(V_{REF} \times \frac{R2}{R1 + R2} \right)$	Outputs from +4 to +250 volts <i>(Figure 7)</i> $V_{OUT} = \left(\frac{V_{REF}}{2} \times \frac{R2 - R1}{R1} \right); R3 = R4$	Current Limiting $I_{LIMIT} = \frac{V_{SENSE}}{R_{SC}}$
Outputs from +7 to +37 volts <i>(Figures 2, 4, 5, 6, 9, 12)</i> $V_{OUT} = \left(V_{REF} \times \frac{R1 + R2}{R2} \right)$	Outputs from -6 to -250 volts <i>(Figures 3, 8, 10)</i> $V_{OUT} = \left(\frac{V_{REF}}{2} \times \frac{R1 + R2}{R1} \right); R3 = R4$	Foldback Current Limiting $I_{KNEE} = \left(\frac{V_{OUT} R3}{R_{SC} R4} + \frac{V_{SENSE} (R3 + R4)}{R_{SC} R4} \right)$ $I_{SHORT\ CKT} = \left(\frac{V_{SENSE}}{R_{SC}} \times \frac{R3 + R4}{R4} \right)$

Typical Applications

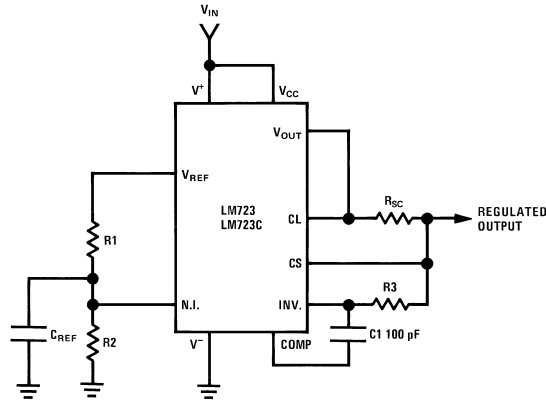

20125808

Note: $R3 = \frac{R1 R2}{R1 + R2}$

for minimum temperature drift

Typical Performance

Regulated Output Voltage	5V
Line Regulation ($\Delta V_{IN} = 3V$)	0.5mV
Load Regulation ($\Delta I_L = 50 \text{ mA}$)	1.5mV

FIGURE 1. Basic Low Voltage Regulator
($V_{OUT} = 2 \text{ to } 7 \text{ Volts}$)

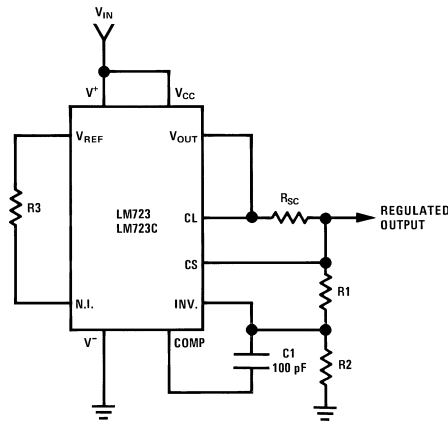

20125809

Note: $R3 = \frac{R1 R2}{R1 + R2}$

for minimum temperature drift.

R3 may be eliminated for minimum component count.

Typical Performance

Regulated Output Voltage	15V
Line Regulation ($\Delta V_{IN} = 3V$)	1.5 mV
Load Regulation ($\Delta I_L = 50 \text{ mA}$)	4.5 mV

FIGURE 2. Basic High Voltage Regulator
($V_{OUT} = 7 \text{ to } 37 \text{ Volts}$)

Typical Applications (Continued)

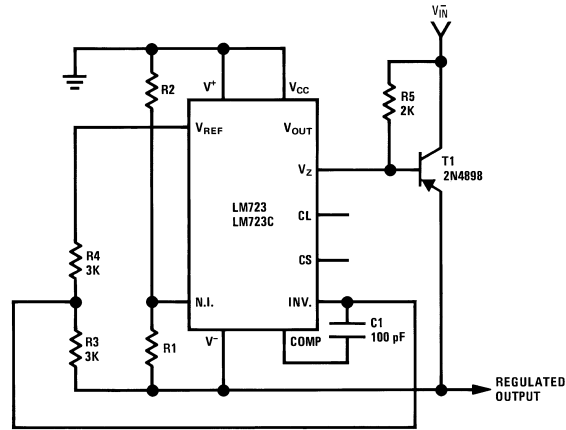

20125810

Typical Performance

Regulated Output Voltage	-15V
Line Regulation ($\Delta V_{IN} = 3V$)	1 mV
Load Regulation ($\Delta I_L = 100 \text{ mA}$)	2 mV

FIGURE 3. Negative Voltage Regulator

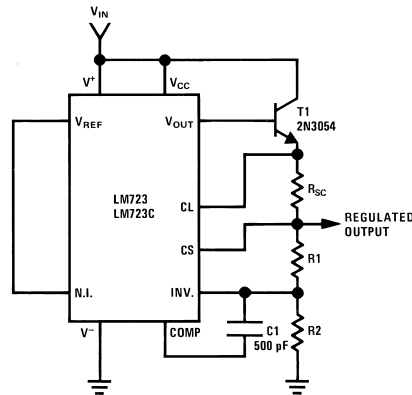

20125811

Typical Performance

Regulated Output Voltage	+15V
Line Regulation ($\Delta V_{IN} = 3V$)	1.5 mV
Load Regulation ($\Delta I_L = 1A$)	15 mV

FIGURE 4. Positive Voltage Regulator
(External NPN Pass Transistor)

Typical Applications (Continued)

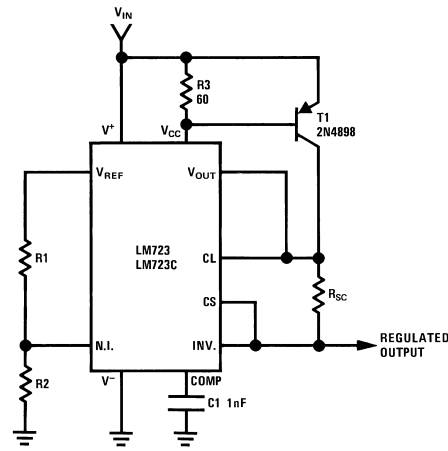

20125812

Typical Performance

Regulated Output Voltage	+5V
Line Regulation ($\Delta V_{IN} = 3V$)	0.5 mV
Load Regulation ($\Delta I_L = 1A$)	5 mV

FIGURE 5. Positive Voltage Regulator (External PNP Pass Transistor)

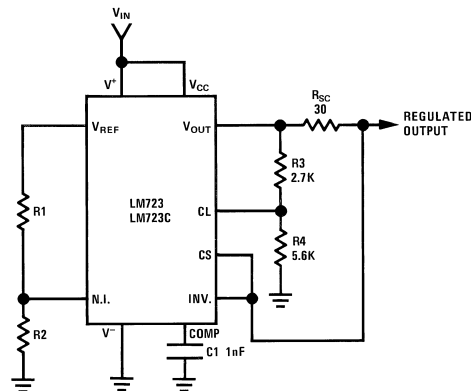

20125813

Typical Performance

Regulated Output Voltage	+5V
Line Regulation ($\Delta V_{IN} = 3V$)	0.5 mV
Load Regulation ($\Delta I_L = 10 \text{ mA}$)	1 mV
Short Circuit Current	20 mA

FIGURE 6. Foldback Current Limiting

Typical Applications (Continued)

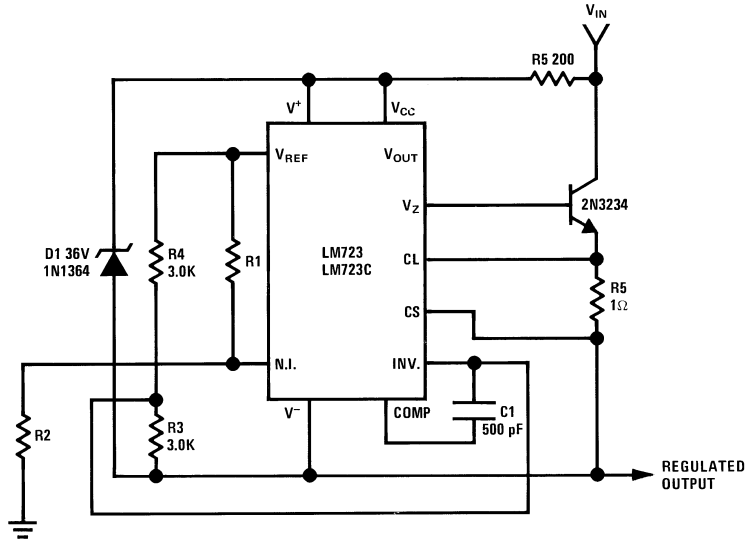

20125814

Typical Performance

Regulated Output Voltage	+50V
Line Regulation ($\Delta V_{IN} = 20V$)	15 mV
Load Regulation ($\Delta I_L = 50 \text{ mA}$)	20 mV

FIGURE 7. Positive Floating Regulator

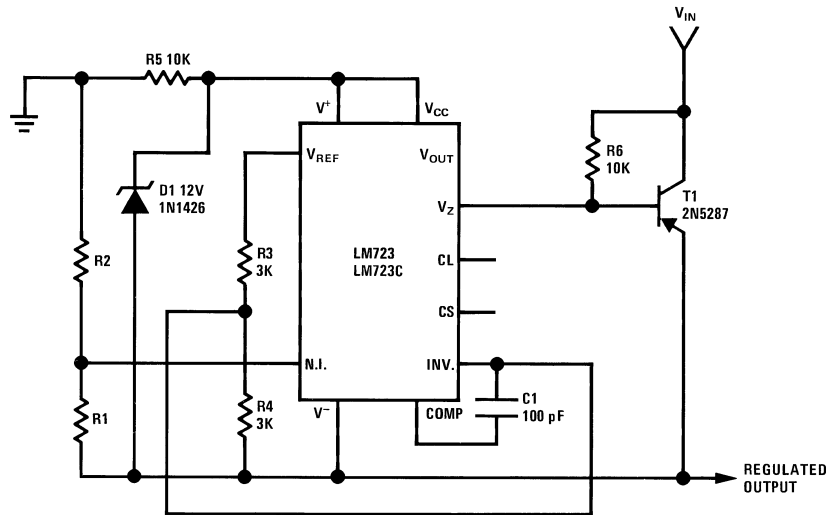

20125815

Typical Performance

Regulated Output Voltage	-100V
Line Regulation ($\Delta V_{IN} = 20V$)	30 mV
Load Regulation ($\Delta I_L = 100 \text{ mA}$)	20 mV

FIGURE 8. Negative Floating Regulator

Typical Applications (Continued)

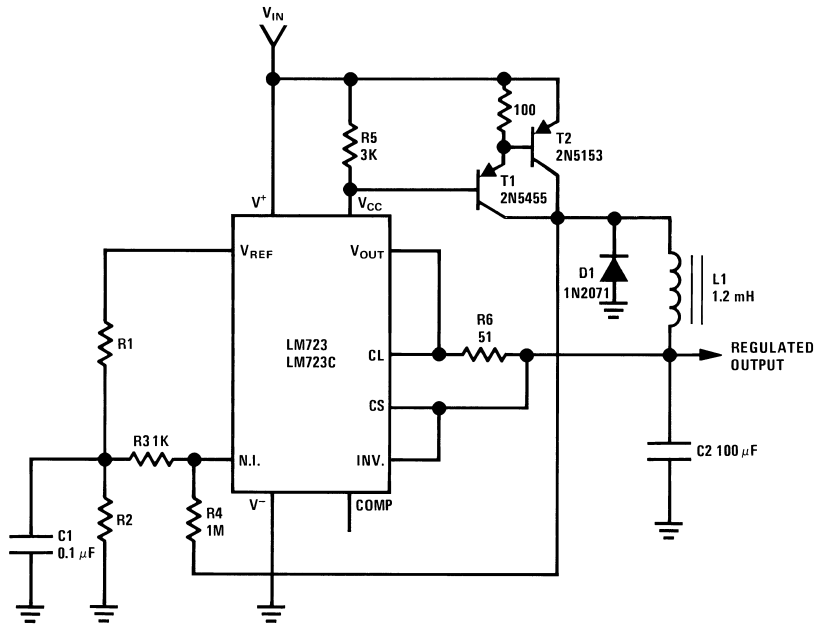

20125816

Typical Performance

Regulated Output Voltage	+5V
Line Regulation ($\Delta V_{IN} = 30V$)	10 mV
Load Regulation ($\Delta I_L = 2A$)	80 mV

FIGURE 9. Positive Switching Regulator(Note 4)

Typical Applications (Continued)

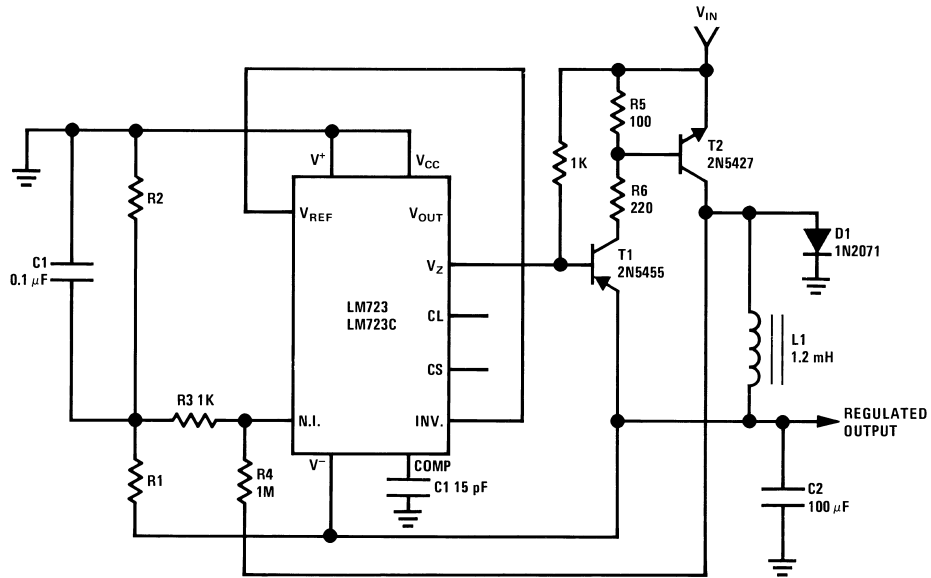

20125817

Typical Performance

Regulated Output Voltage	-15V
Line Regulation ($\Delta V_{IN} = 20V$)	8 mV
Load Regulation ($\Delta I_L = 2A$)	6 mV

FIGURE 10. Negative Switching Regulator(Note 4)

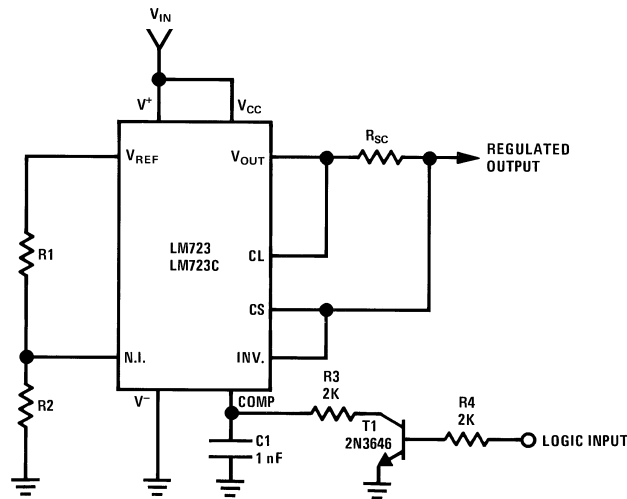

20125818

Note: Current limit transistor may be used for shutdown if current limiting is not required.

Typical Performance

Regulated Output Voltage	+5V
Line Regulation ($\Delta V_{IN} = 3V$)	0.5 mV
Load Regulation ($\Delta I_L = 50 mA$)	1.5 mV

FIGURE 11. Remote Shutdown Regulator with Current Limiting

Typical Applications (Continued)

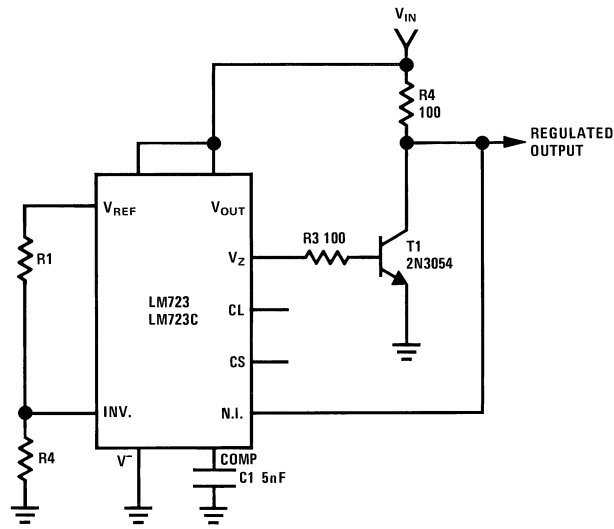

20125819

Regulated Output Voltage	+5V
Line Regulation ($\Delta V_{IN} = 10V$)	0.5 mV
Load Regulation ($\Delta I_L = 100 \text{ mA}$)	1.5 mV

FIGURE 12. Shunt Regulator

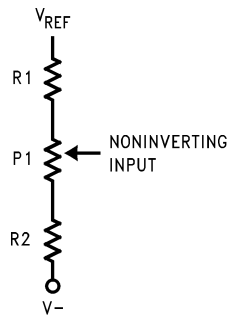

20125821

FIGURE 13. Output Voltage Adjust
(Note 6)

Revision History Section

Date Released	Revision	Section	Originator	Changes
02/15/05	A	New Release, Corporate format	L. Lytle	1 MDS data sheet converted into one Corp. data sheet format. MJLM723-X, Rev. 1A0. MDS data sheet will be archived.

Physical Dimensions inches (millimeters) unless otherwise noted

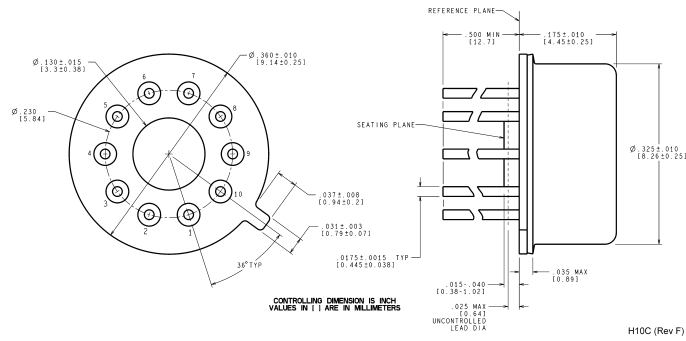

**Metal Can Package (H)
NS Package H10C**

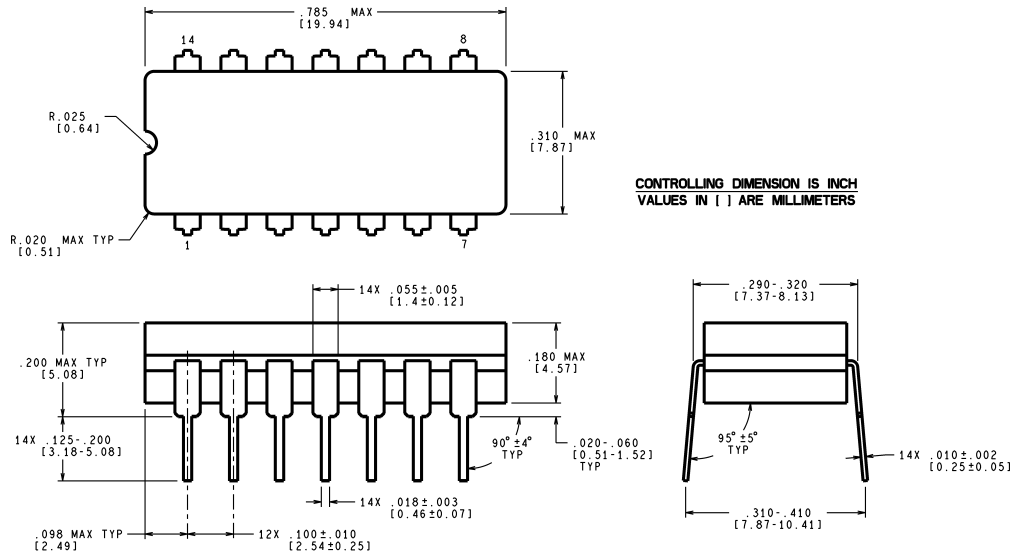

**Ceramic Dual-In-Line Package (J)
NS Package J14A**

National does not assume any responsibility for use of any circuitry described, no circuit patent licenses are implied and National reserves the right at any time without notice to change said circuitry and specifications.

For the most current product information visit us at www.national.com.

LIFE SUPPORT POLICY

NATIONAL'S PRODUCTS ARE NOT AUTHORIZED FOR USE AS CRITICAL COMPONENTS IN LIFE SUPPORT DEVICES OR SYSTEMS WITHOUT THE EXPRESS WRITTEN APPROVAL OF THE PRESIDENT AND GENERAL COUNSEL OF NATIONAL SEMICONDUCTOR CORPORATION. As used herein:

1. Life support devices or systems are devices or systems which, (a) are intended for surgical implant into the body, or (b) support or sustain life, and whose failure to perform when properly used in accordance with instructions for use provided in the labeling, can be reasonably expected to result in a significant injury to the user.
2. A critical component is any component of a life support device or system whose failure to perform can be reasonably expected to cause the failure of the life support device or system, or to affect its safety or effectiveness.

BANNED SUBSTANCE COMPLIANCE

National Semiconductor manufactures products and uses packing materials that meet the provisions of the Customer Products Stewardship Specification (CSP-9-111C2) and the Banned Substances and Materials of Interest Specification (CSP-9-111S2) and contain no "Banned Substances" as defined in CSP-9-111S2.



National Semiconductor
Americas Customer
Support Center
Email: new.feedback@nsc.com
Tel: 1-800-272-9959

www.national.com

National Semiconductor
Europe Customer Support Center
Fax: +49 (0) 180-530 85 86
Email: europe.support@nsc.com
Deutsch Tel: +49 (0) 69 9508 6208
English Tel: +44 (0) 870 24 0 2171
Français Tel: +33 (0) 1 41 91 8790

National Semiconductor
Asia Pacific Customer
Support Center
Email: ap.support@nsc.com

National Semiconductor
Japan Customer Support Center
Fax: 81-3-5639-7507
Email: jpn.feedback@nsc.com
Tel: 81-3-5639-7560